



SPARE PARTS EXPLODED VIEW
STORAGE ELECTRIC WATER HEATERS
Model
ABSE VLS PRO INOX PW

R8218950-02 - 05/04/2023

ABSE VLS PRO INOX PW

Storage Electric Water Heaters

| 1 | 3700677 | ABSE VLS PRO INOX PW 30 | 04-2021 | 08-2023 |
|-----|-----------|--------------------------|---------|---------|
| 2 | 3700678 | ABSE VLS PRO INOX PW 50 | 04-2021 | - |
| 3 | 3700679 | ABSE VLS PRO INOX PW 80 | 04-2021 | - |
| 4 | 3700680 | ABSE VLS PRO INOX PW 100 | 04-2021 | - |
| Col | Reference | Model type | Begin | End |

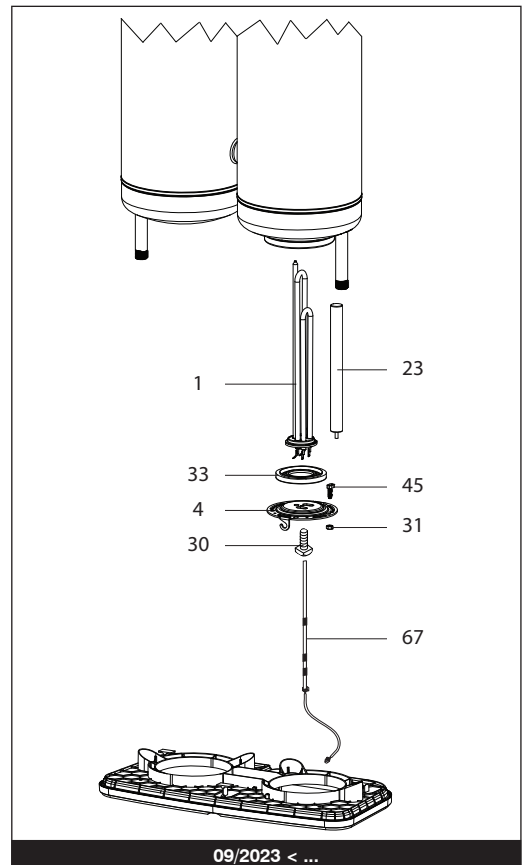
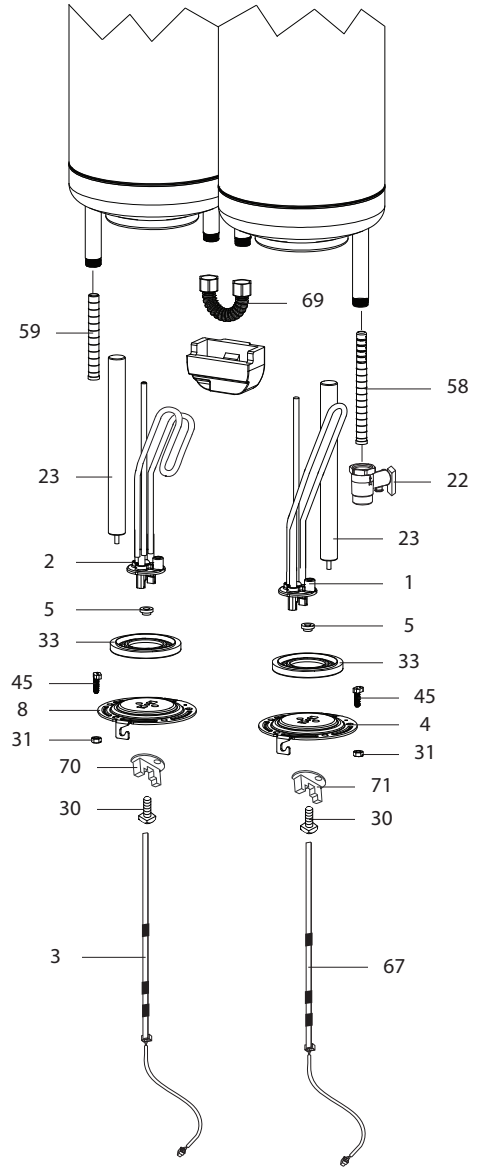
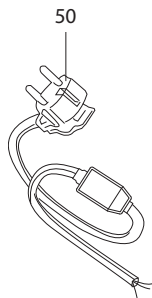
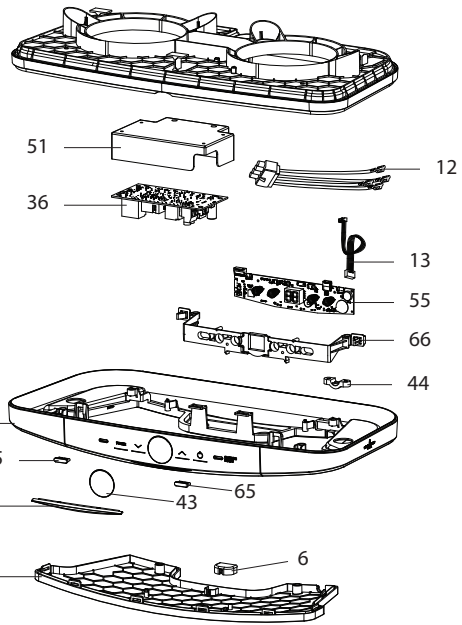
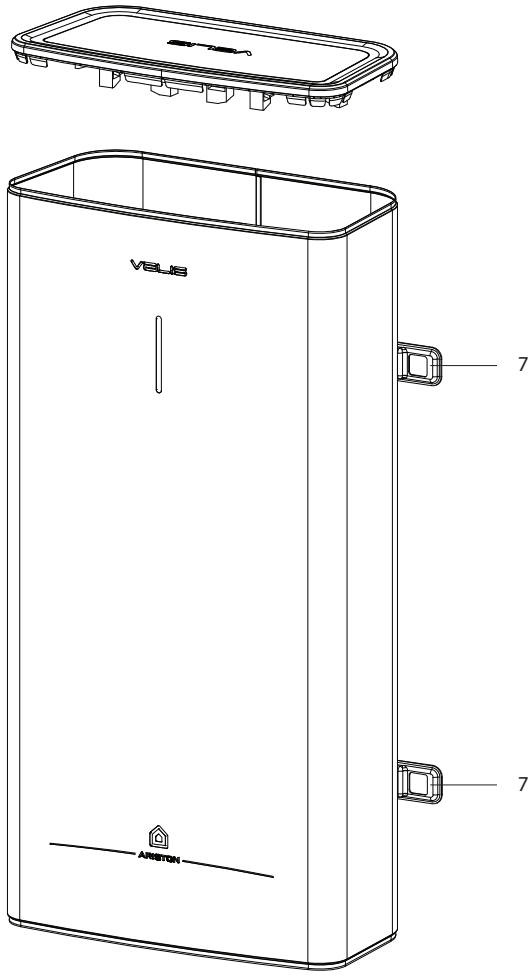

09/2023 < ...

LIST OF THE ABBREVIATIONS

| | |
|-------------|--|
| HW | : Hot water. |
| CW | : Cold water. |
| C | : Ceramic resistance (normal heating). |
| Ca | : Ceramic resistance (accelerated heating) |
| TP | : Immersion heater. |
| 1F | : With fittings. |
| 2F | : Without fittings. |
| 3F | : With fittings and another outlet connection. |
| AMI | : With mixing valve. |
| SMI | : Without mixing valve. |
| PUISS | : Power of th appliance. |
| PN | : Appliance with normal pression. |
| LP | : Appliance with low pression. |
| PV | : Appliance with variable power. |
| PF | : Appliance with fixed power. |

IDENTIFICATION PLATE

SERIAL NUMBER

6 Characters :
 Year of manufacture 03 09 08 Manufacturing day
 Month of manufacture

9 Characters :
 Year of manufacture 5 9 12 0606 Sequential number
 Month of manufacture

14 Characters :

SI-V-0B0 45 07 0001
 Sequential number
 Year of manufacture : → 6 → 2004
 Month of manufacture : → 25 → January 43 → July 7 → 2005
 → 13 → February 29 → August 8 → 2006
 → 32 → March 40 → September etc ...
 → 35 → April 38 → October
 → 39 → May 51 → November
 → 45 → June 12 → December

14 Characters :
 111518 XX 000010
 Month of manufacture Sequential number
 Day of manufacture Year of manufacture

15 Characters :
 02 11 00001 007843
 Year of manufacture Product reference
 Month of manufacture Sequential number

21 Characters :
 3200050 XX 08115 0000001
 Product reference Sequential number
 Year (08) / Manufacturing day (115)

22 Characters :
 3200050 XX 070115 0000001
 Product reference Sequential number
 Year (07) / Month (01) / Manufacturing day (15)